

FR HYDRAULIC RANGE DP

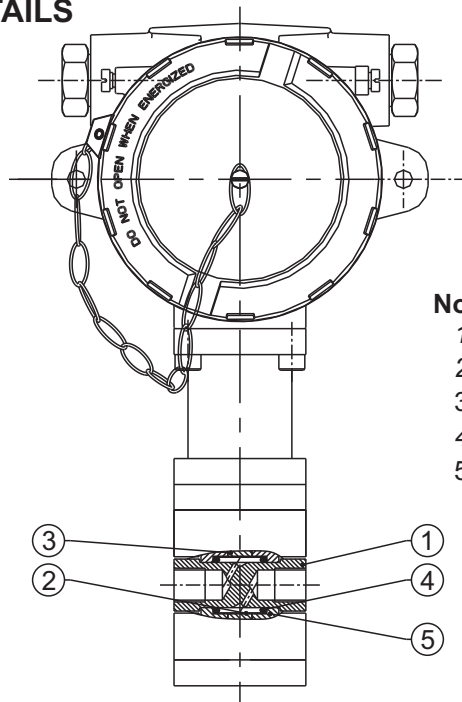

PRESSURE CAPSULE DETAILS



- | No. | Description |
|-----|------------------|
| 1. | Pressure Housing |
| 2. | Diaphragm |
| 3. | Plunger |
| 4. | O-Ring |
| 5. | Disc |

Note : wetted parts are mentioned in italics.

INSTALLATION DRAWING

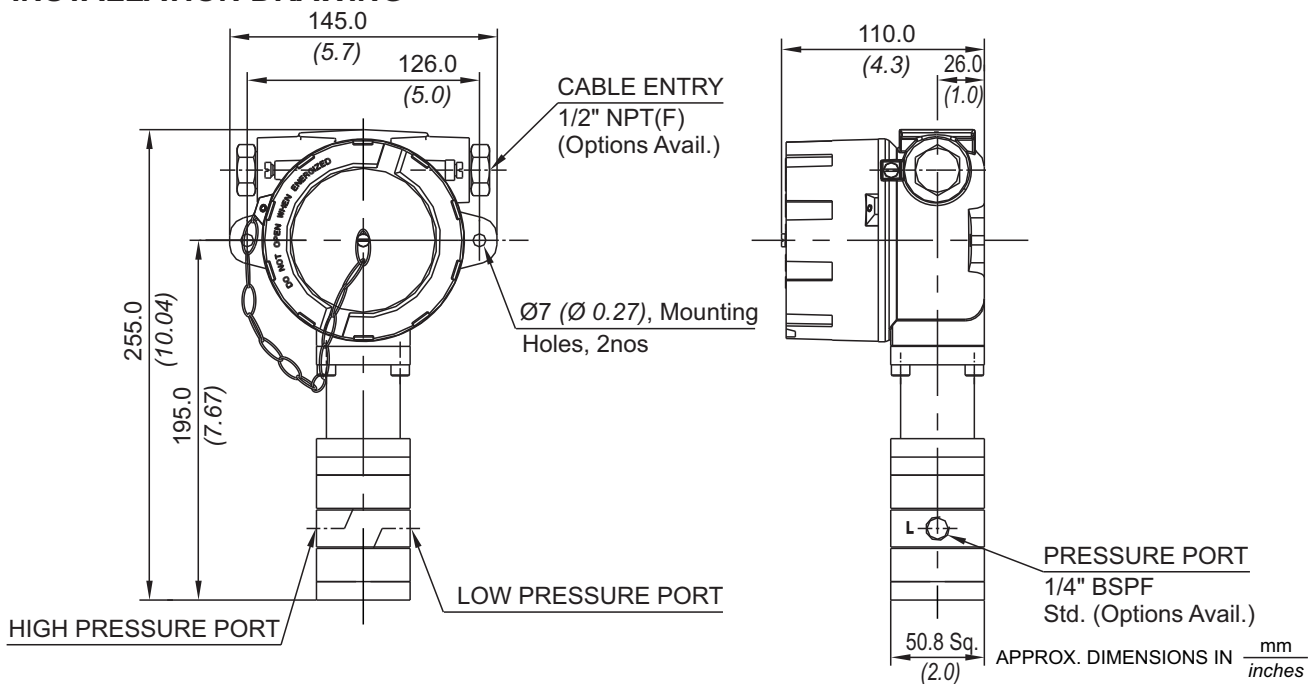

RANGE SELECTION TABLE

Range Code	Range bar (psi)	Differential* bar (psi)	Maximum Working Pressure bar (psi)
		Approximate Maximum for "A1" microswitch	
H1U	0.1 to 1.0 (1.45 to 14.50)	0.30 (4.35)	150.0 (2175.57)
H2U	0.1 to 1.5 (1.45 to 21.75)	0.30 (4.35)	150.0 (2175.57)
H3U	0.2 to 2.6 (2.90 to 37.70)	0.40 (5.8)	150.0 (2175.57)
H4U	0.2 to 3.6 (2.90 to 52.21)	0.60 (8.70)	150.0 (2175.57)
H7U	0.5 to 7.0 (7.25 to 101.53)	1.0 (14.50)	150.0 (2175.57)
D1T	0.5 to 10.0 (7.25 to 145.04)	1.5 (21.75)	200.0 (2900.75)
D2T	1.0 to 15.0 (14.50 to 217.56)	3.0 (43.51)	200.0 (2900.75)
D3T	5.0 to 25.0 (72.52 to 362.60)	4.0 (58.01)	200.0 (2900.75)
D4T	5.0 to 40.0 (72.52 to 580.15)	5.0 (72.52)	400.0 (5801.51)
D1H	10 to 100 (145.4 to 1450.38)	12.0 (174.04)	400.0 (5801.51)
D2H	7.0 to 200 (101.53 to 2900.75)	24.0 (348.10)	400.0 (5801.51)
D4H	40.0 to 400 (580.151 to 5801.51)	70.0 (1015.26)	500.0 (7251.89)

Note:

1. The minimum differential increases with the setpoint. The differential values mentioned in the above table are approximate maximum for FSR. The differential value will vary according to the pressure range selected and microswitch type. For actual values of differential please contact sales office.

2. When using 2SPDT switching arrangement, both microswitches may not actuate and/or deactuate at the same point. A small stage gap, normally upto +/- 5% FSR (depending on range code) may be observed. The On-Off differential (hysteresis) typically tends to be atleast double of those published for 1SPDT pressure switches.

If actuation and/or deactuation at same point is critical part of operation, then it can be achieved by using a separate DPDT relay. This relay will need a separate power supply for it's coil.

Intrinsic Safety (Exia) : Pressure and temperature switches are classified as simple apparatus, as per IEC 60079-11, as they neither store or generate energy. Hence switches can be used in intrinsically safe systems provided the power source is IS certified. Because of low voltages and current it is recommended to use hermetically sealed microswitches / microswitches.

HOW TO ORDER FLAMEPROOF HYDRAULIC RANGE DP SWITCHES

HYDRAULIC RANGE DP

FR

Group 1	Group 2	Group 3	Group 4	Group 5	Group 6	Group 7	Group 8								
Non standard allocation	Model	Cable Entry Size	Switch Type	Range Code (values in bar)	Microswitch Type	Pressure Port Material / Size	Diaphragm								
<p>□ A prefix "N" is used in the model code in case of any non standard options / accessories that are provided with the switches. Will be given by manufacturer, only after agreement of supply details with customer.</p> <p>The prefix is subject to change as per specific requirement.</p> <p>Approx. switch weight in Kgs</p> <table border="1"> <tr><td>Enclosure</td><td>FR</td></tr> <tr><td>Aluminium</td><td>1.950</td></tr> <tr><td>Grey CI</td><td>4.350</td></tr> <tr><td>SS</td><td>4.450</td></tr> </table>	Enclosure	FR	Aluminium	1.950	Grey CI	4.350	SS	4.450	<p>FR = IP66 Flameproof pressure switch, EAC approved</p>	<p>1 = Al. head 1/2" NPT threads 2 = Al. head 3/4" NPT threads 3 = Al. head M20 x 1.5 threads *4 = Grey CI head 1/2" NPT threads *5 = Grey CI head 3/4" NPT threads *6 = Grey CI head M20 x 1.5 threads 7 = SS head 1/2" NPT threads 8 = SS head 3/4" NPT threads 9 = SS head M20 x 1.5 threads</p>	<p>D1 = pressure difference switch, fixed differential without scale D2 = pressure difference switch, fixed differential with scale in bar D3 = pressure difference switch, fixed differential with scale in psi</p> <p>For adjustable differential please select microswitch A6 in group 6</p>	<p>H1U = (0.1 - 1.0) H2U = (0.1 - 1.5) H3U = (0.2 - 2.6) H4U = (0.2 - 3.6) H7U = (0.5 - 7.0) D1T = (0.5 - 10.0) D2T = (1.0 - 15.0) D3T = (5.0 - 25.0) D4T = (5.0 - 40.0) D1H = (10 - 100) D2H = (7.0 - 200) D4H = (40 - 400)</p>	<p>A1 = General purpose microswitch rated at 15 A; 250 VAC *A6 = elements with adjustable deadband *A7 = 2SPDT switching elements A8 = General purpose microswitch rated at 5 A, 250 VAC; 5 A, 28 VDC B1 = Low differential microswitch rated at 15 A; 250 VAC; 5 A; 28 VDC</p> <p>Please refer to page nos. 120 & 121 for options and specifications of microswitches * Please contact sales office for additional information Please check the note under Range Selection Table for Exi applications.</p>	<p>S1 = SS316 / 1/4" BSP(F) S2 = SS316 / 1/4" NPT(F) H1 = Hastelloy C / 1/4" BSP(F) H2 = Hastelloy C / 1/4" NPT(F) N1 = Monel / 1/4" BSP(F) N2 = Monel / 1/4" NPT(F)</p> <p>More options available, please contact sales office</p>	<p>*0 = Neoprene *1 = PTFE 2 = SS 316L 3 = Hastelloy C 4 = Monel</p> <p>*In case of non-metallic diaphragms the ambient temperature range should be (-)20° to 60° C.</p> <p>For additional wetted parts please contact Sales Office</p>
Enclosure	FR														
Aluminium	1.950														
Grey CI	4.350														
SS	4.450														

eg. A flameproof switch for gas group IIC, with 1/2" NPT cable entry in aluminium housing as 1SPDT pressure difference switch, having 0.1 bar to 1 bar pressure range, with 15Amp. microswitch, SS316 pressure housing with 1/4" BSP port size & neoprene diaphragm shall be specified by

Group 1	Group 2	Group 3	Group 4	Group 5	Group 6	Group 7	Group 8
□	FR	1	D1	H1U	A1	S1	0

Please specify full model number to avoid ambiguity. If only the first two groups are specified while ordering, uncalibrated switches with standard wetted parts and enclosures will be supplied.